



Schreiber

Tempe, Arizona

# CHEMICAL CONTAINMENT Flooring Solutions

**Brilliant Epoxy Floors**  
www.brilliantaz.com  
480-203-2444  
info@brilliantaz.com  
ROC AZ323537 NV0092191



# CHEMICAL CONTAINMENT CHARACTERISTICS

**EXCELLENT CHEMICAL RESISTANCE** - Our chemical containment flooring systems are highly resistant to a wide range of chemicals including alkalis, acids, solvents, and other hazardous substances. This resistance prevents the flooring from deteriorating or corroding.

**SAFETY COMPLIANCE** - By containing spills and resisting chemicals, our chemical containment flooring systems help facilities comply with safety regulations and standards, such as those set by environmental agencies or occupational health and safety organizations. This reduces the risk of regulatory fines or penalties associated with chemical handling and containment.

**EASY MAINTENANCE** - Chemical containment flooring is designed for easy cleaning and maintenance. Spills can be quickly and easily wiped up without causing any damage to the flooring, ensuring a safe and hygienic environment.

**VERSATILITY & ADAPTABILITY** - All our chemical containment flooring solutions can be applied to a variety of substrates, including concrete and metal, and can be customized to meet specific performance requirements, such as enhanced flexibility or increased thermal stability. This adaptability allows for tailored solutions that perfectly fit the unique needs of each chemical containment application, ensuring optimal performance and protection.



# OUR SOLUTIONS

## Thin Mil- CT-3VeVeVef

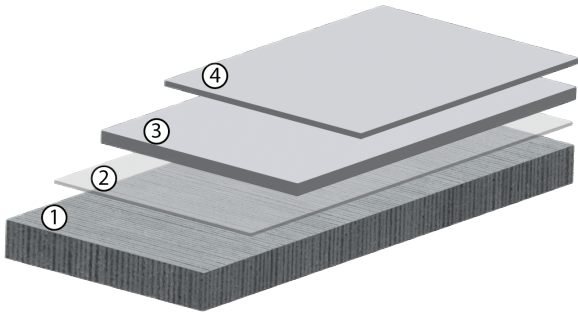

1. Prepared Concrete
2. Vinyl Ester
3. Vinyl Ester
4. Vinyl Ester Flake

Impact Resistance



## Broadcast - BC-4VeVeAVef

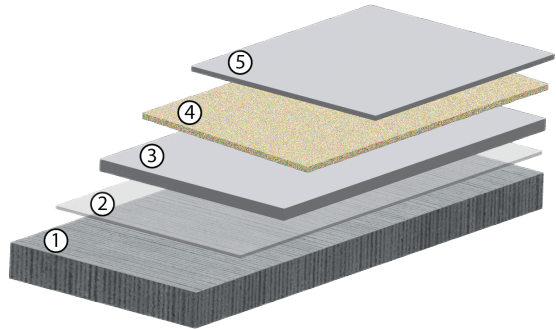

1. Prepared Concrete
2. Vinyl Ester
3. Vinyl Ester
4. Aggregate Sand Broadcast
5. Vinyl Ester Flake

Impact Resistance



## Slurry - SL-4UcVeVeVef

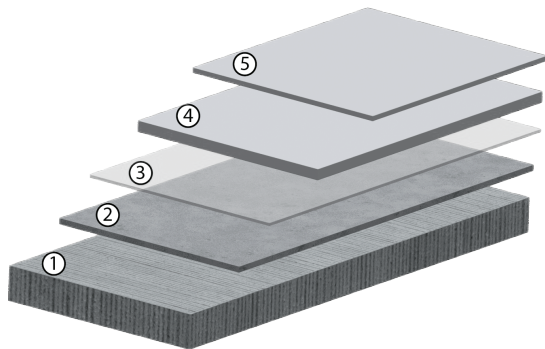

1. Prepared Concrete
2. Urethane Cement
3. Vinyl Ester
4. Vinyl Ester
5. Vinyl Ester Flake

Impact Resistance



## Mortar - MT-4MVeVeVef

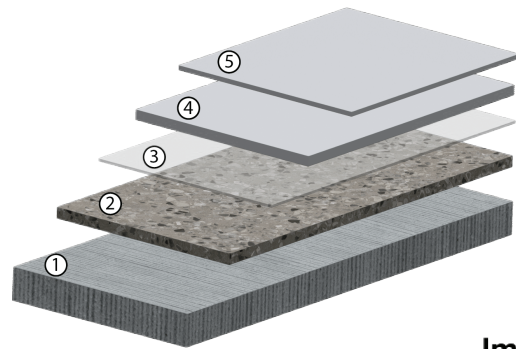

1. Prepared Concrete
2. Mortar Mixture
3. Vinyl Ester
4. Vinyl Ester
5. Vinyl Ester Flake

Impact Resistance



Brilliant Epoxy Floors offers a wide variety of chemical containment flooring systems. Our flooring experts will evaluate your facility to determine which system best matches your flooring needs.



Daisy Brand



SRP



Schreiber



Ford Plant



Optiforms

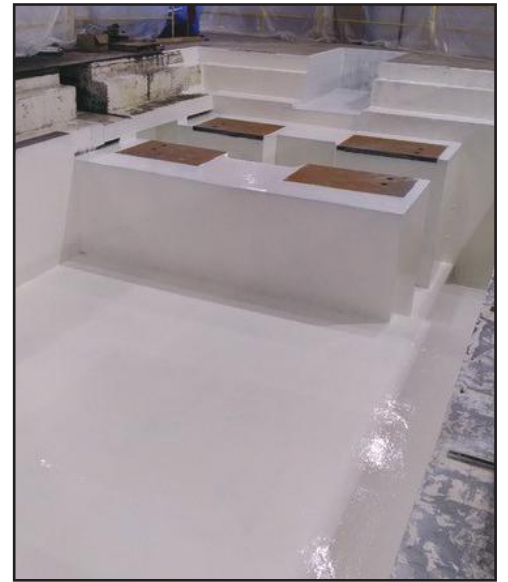

Private Client



**Brilliant Epoxy Floors**

[www.brilliantaz.com](http://www.brilliantaz.com)

480-203-2444

[info@brilliantaz.com](mailto:info@brilliantaz.com)

ROC AZ323537 NV0092191